

Kuhl Road, P.O. Box 26
 Flemington, N.J 08822-0026 U.S.A.
 Phone: 908/782-5696
 Telefax 908/782-2751

A corporation devoted exclusively to the sales and service of Kuhl Poultry Equipment, Egg Handling Equipment and Specialized Equipment for the Food Processing Industry.

UNI-MATIC-100 / BELL-MATIC AUTOMATIC HANGING WATERER

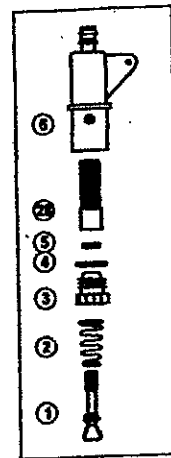
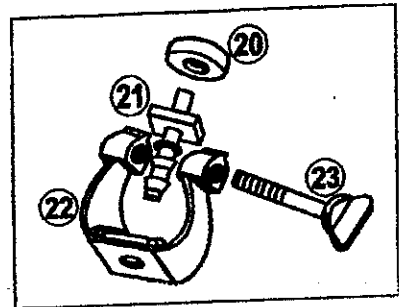
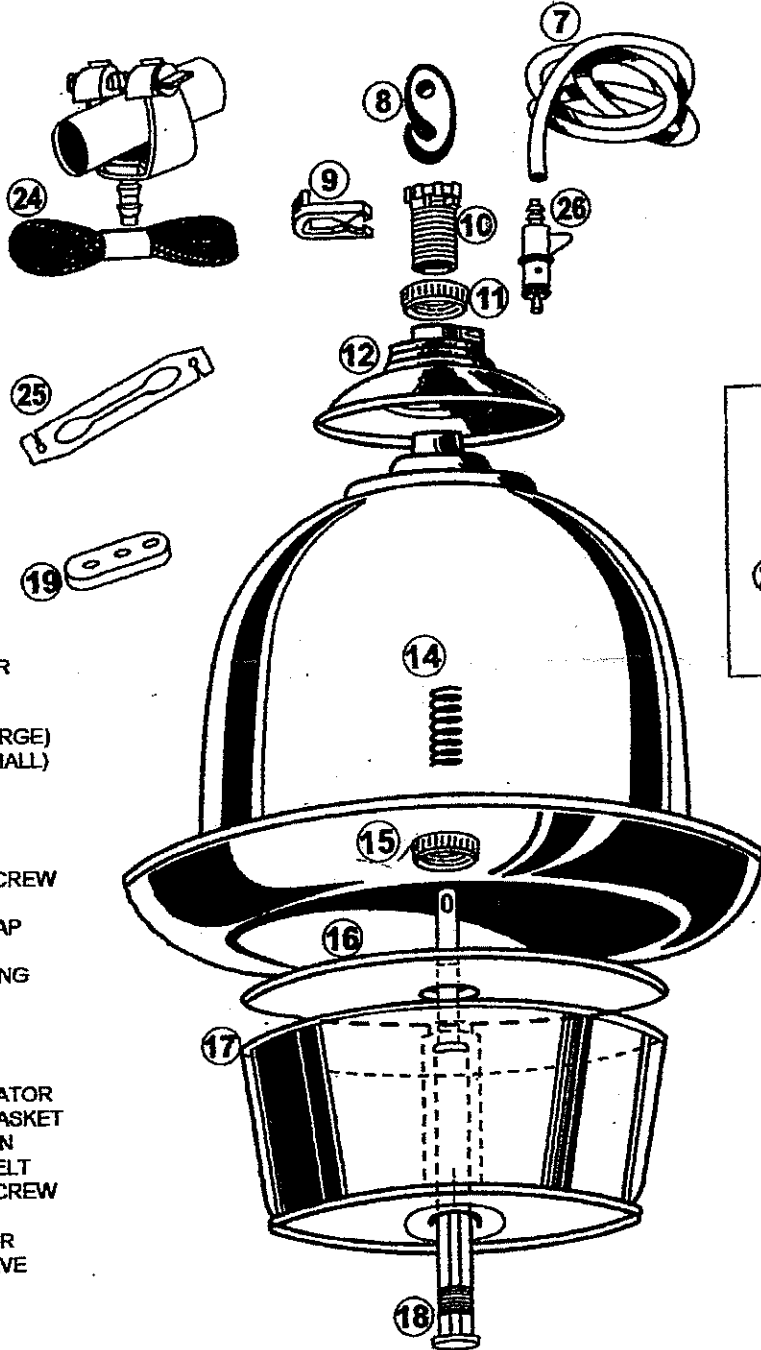

- 1 VALVE ACTUATOR
- 2 TAPER SPRING
- 3 VALVE CAP
- 4 O-RING 2-113 (LARGE)
- 5 O-RING 2-201 (SMALL)
- 6 VALVE BODY
- 7 HOSE
- 8 HANGING HOOK
- 9 LOCKING TAB
- 10 REGULATING SCREW
- 11 NUT A
- 12 REGULATING CAP
- 13 PLASTIC BELL
- 14 STRAIGHT SPRING
- 15 NUT B
- 16 WEIGHT CAP
- 17 WEIGHT
- 18 CENTRAL ROD
- 19 HEIGHT REGULATOR
- 20 CONNECTOR GASKET
- 21 CONNECTOR PIN
- 22 CONNECTOR BELT
- 23 CONNECTOR SCREW
- 24 ROPE
- 25 HOSE FASTENER
- 26 COMPLETE VALVE
- 28 FILTER

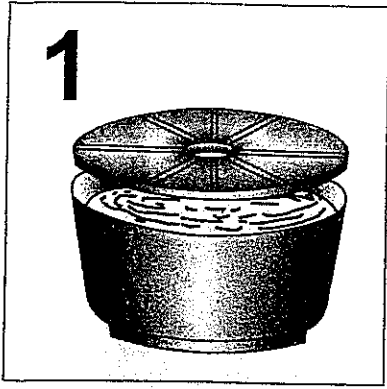

1. Fill the weight up with water and close it with the cap.

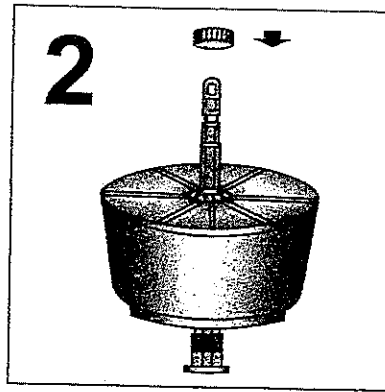

2. Insert the central rod through the weight and lock it with #11 nut.

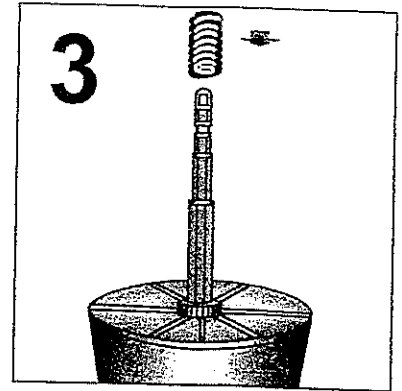

3. Insert the straight spring on the central rod up to its position.

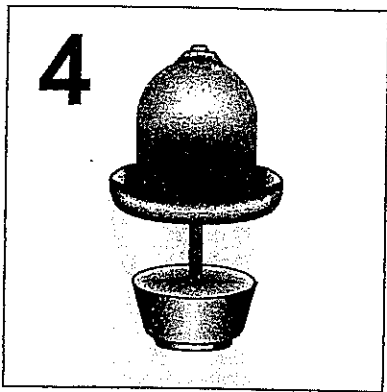

4. Insert the plastic bell over the central rod.

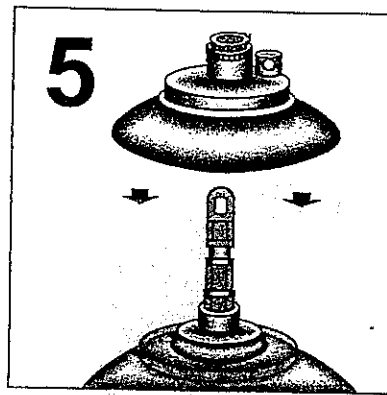

5. Insert the valve assembly on the rod, make sure that the locking tab has locked onto the rod by pulling the assy. (it should be locked into position)

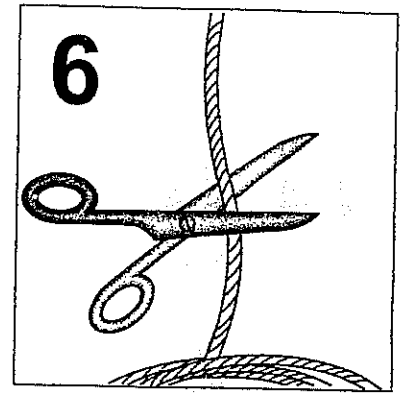

6. Cut rope at 118" to hang the drinker.

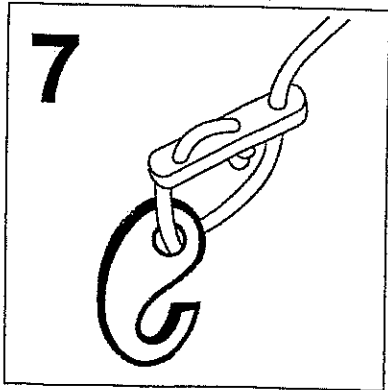

7. Assemble hanger hook and height regulator onto the rope.

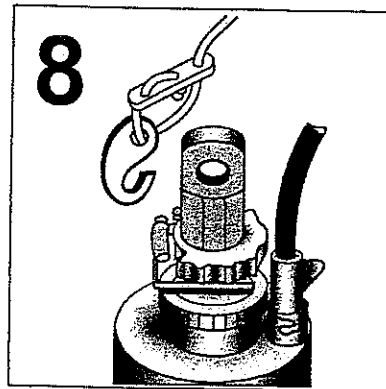

8. Hang the drinker with the hook.

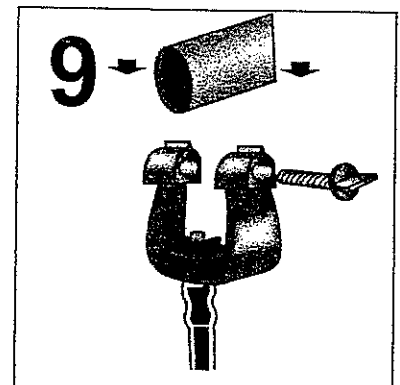

9. Installation of the connector on the water line. Drill holes 5/16" on the water pipe.

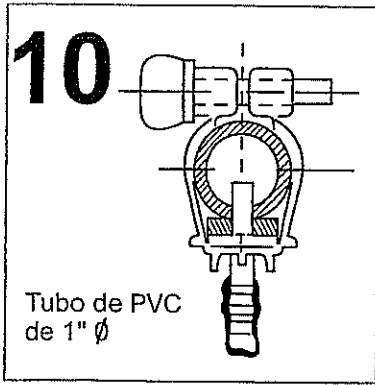

10. To install the connector on 1" pipe, use with 1" marks on inside.

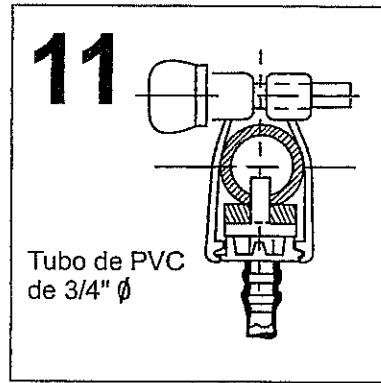

11. To install the connector on 3/4" pipe, use with 3/4" marks on inside.

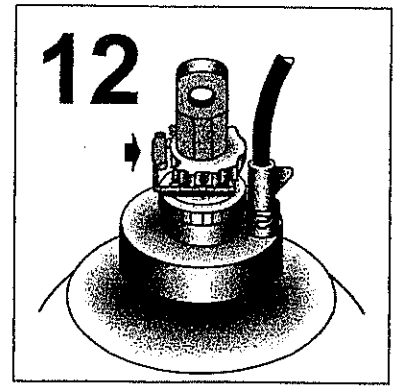

12. To pull out the valve, turn it counterclockwise. To set it back, push it in and turn it clockwise.

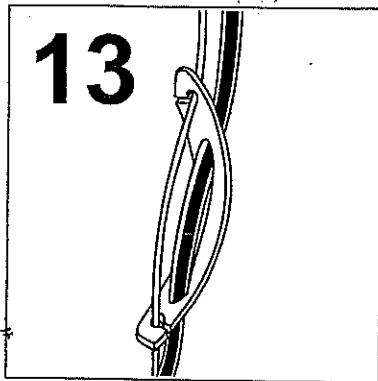

13. Fasten the hose and rope using the hose fastener, as shown.

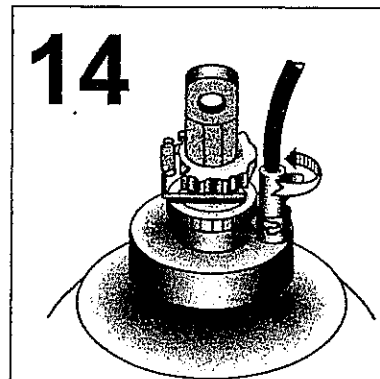

14. In order to clean drinker, you don't have to shut off the water. Simply pull the valve (26) off and let it hang. The valve will close and not allow any leakage.

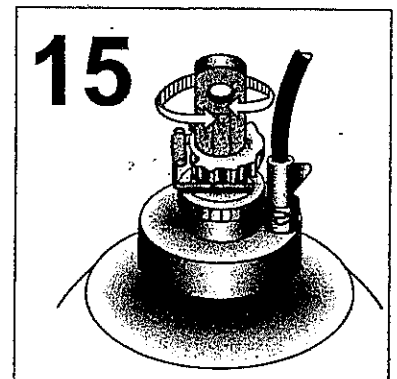

15. To regulate water level simply turn the regulating screw counterclockwise to increase the water level. Turn it clockwise to reduce the water level.

IT IS SUGGESTED THAT THE WATERER IS TO BE USED WITH 6 LBS PSI WATER PRESSURE. OUR #PR200G PRESSURE REGULATOR, SOLD SEPARATELY, CAN BE USED TO ACHIEVE THIS.